



Model 10A11-1, Rev B Two-Way Audio/Voice Alarm Module

DESCRIPTION

The Model 10A11-1, Rev B Two-Way Audio/Voice Alarm Module allows two-way communication with a central station after an alarm, paging and listening from an on-premises or remote phone, annunciation of alarm and zone by voice, and voice messaging. The Model 10A11-1, Rev B can be used with OmniLT, Omni II, and OmniPro II automation controllers.

FEATURES

- Two independent audio amplifiers
- Two microphone inputs
- Automatic gain control (AGC) for talk and listen
- Two-way or listen-only operation
- Control via standard Touch-Tone phone
- Connects to HAI Speaker/Microphone Modules and/or Omni Consoles with Built-in Speaker/Microphone

INSTALLATION

Connect 8-ohm speaker(s) and two-wire electret microphone(s) to the Model 10A11-1, Rev B - See *Figure 1*. HAI Model 28A00-1 (Surface) or Model 28A00-2 (Flush) Speaker/Microphone Modules and/or Model 33A00-4 Omni Consoles with Built-in Speaker/Microphone can be used.

NOTE: Do not mount speakers, microphones, 28A00 modules, or 33A00-4 consoles near any device that may produce noise (fans, air conditioning units, audio speakers, etc.).

Microphones should be connected with 24 AWG or larger, shielded twisted pair wire. Wire length should not exceed 100 feet. Connect the cable shields and negative wires together at the Model 10A11-1, Rev B terminal block only. **Do not connect the shield on the microphone end.** Additional microphones can be connected to each input in parallel.

Speakers should be connected with 18 AWG or larger, twisted pair wire. For wire runs that exceed 50 feet, use 16 AWG wire or larger. Wire length should not exceed 100 feet. Additional speakers can be connected to each output in series.

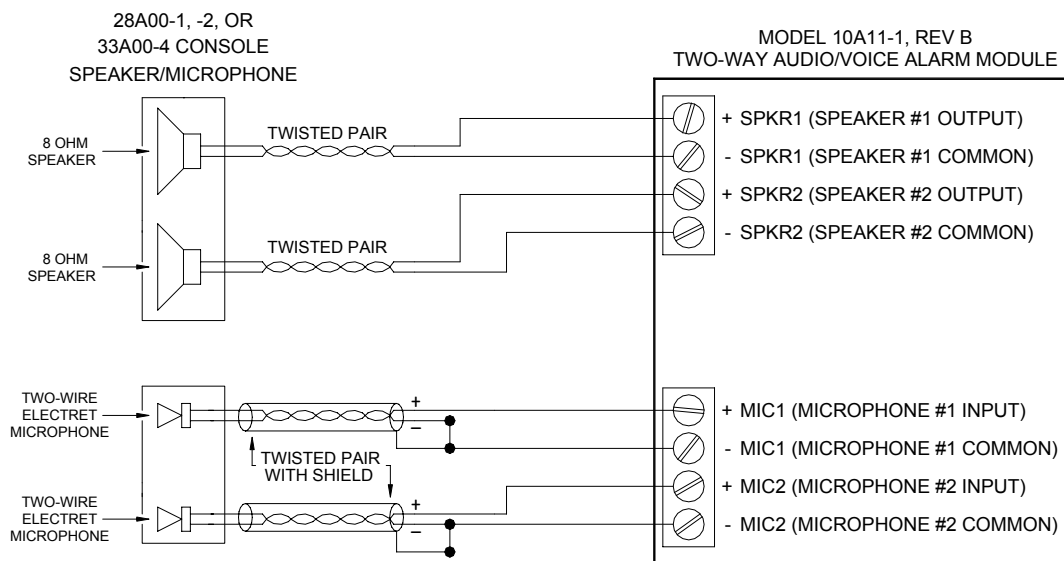

Figure 1 - Speaker/Microphone Connections

MOUNTING

When mounting and connecting the Model 10A11-1, Rev B, **power down the controller** (AC and battery). Connecting the Model 10A11-1, Rev B board, while power is still applied to the controller, can damage the board, the controller, or both.

Mount the Model 10A11-1, Rev B to the upper right side of the enclosure using the supplied adhesive-backed resealable fasteners.

When connecting to an OmniLT, route the cable to the connector on the top of the board marked "J1". Plug the Model 10A11-1, Rev B cable into "J1" on the controller. The red wire should be to the left of the connector (red wire to Pin 1) - See Figure 2. Make sure that the connector is aligned with the pins on "J1".

When connecting to an Omni II or OmniPro II, route the cable along the top of the enclosure to the connector on the left side marked "J2". Plug the Model 10A11-1, Rev B cable into "J2" on the controller. The red wire should be to the top of the connector - See Figure 3. Make sure that the connector is aligned with the pins on "J2".

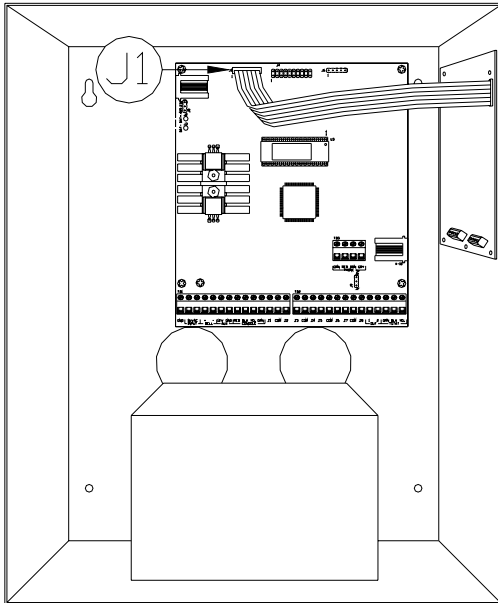

Figure 2 - OmniLT Installation

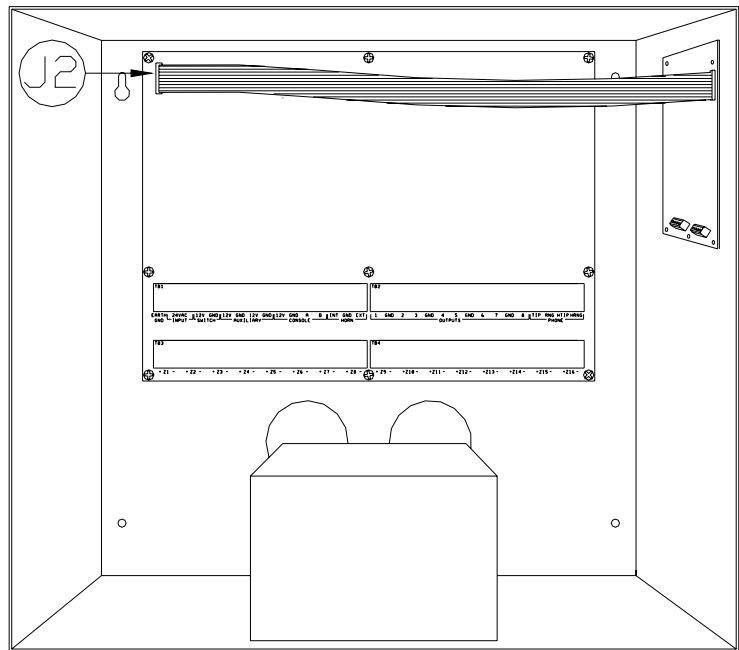

Figure 3 - Omni II / OmniPro II Installation

CONTROLLER SETUP

When using a Model 10A11-1, Rev B for two-way communication with a central station, the Two-Way Voice option must be enabled. From the Installer Setup menu, select the 3 (DCM) key. Press the down arrow (↓) key until you reach the Two-Way Audio option:

```
TWO-WAY AUDIO :      0
0=NO 1=YES          ↓
```

Press 1 (YES), and then press '#' to enable two-way audio communication.

When using a Model 10A11-1, Rev B to announce alarms, the Announce Alarms option must be enabled. To enable this option, from the Setup menu press the 6 (MISC) key. Press the down arrow (↓) key to until you reach the Announce Alarms option:

```
ANNOUNCE ALARMS :   0
0=NO 1=YES          ↓
```

Press 1 (YES), and then press '#' to enable the system announce alarms.

OPERATION

The Two-Way Audio Module has two modes of audio communication:

1. **Listen mode** is used to listen to the premises from an inside, remote, or central station telephone. You cannot talk to anyone on premises in listen mode. Whenever the module is switched on, it is set to the listen mode.
2. **Talk mode** is used to talk to someone on-premises from an inside, remote, or central station telephone. You cannot listen to the premises while in the talk mode.

The mode can be changed between listen and talk by using the keys on a phone. When the module is switched on, a 90 second disconnect timer is started. If no tones are detected within 90 seconds, the module will be switched off. Each time a tone is received, the timer is reset.

CENTRAL STATION OPERATION

When an alarm occurs, the communicator first sends the appropriate report to the central station. After the transmission of the alarm to the central station, the operator can talk and listen to people and sounds at the premises.

After the report is received by the central station operator, the Two-Way Audio Module is switched on. The central station operator can now listen to the premises. The module is always first switched on in the listen mode. The operator can control the direction of the communication by using the Touch-Tones on a telephone. Each time the operator switches between the listen and the talk mode, a short tone will sound over the audio speaker at the subscriber's premises. This alerts the subscriber that the operator has switched communication mode. If no tones are detected within 90 seconds, the module will disconnect from the phone line.

PRESS 2 FOR CENTRAL STATION TO TALK TO THE PREMISES

PRESS 8 FOR CENTRAL STATION TO LISTEN TO THE PREMISES

PRESS 4 TO DISCONNECT (HANG UP) THE PHONE LINE

When the Two-Way Audio Module is switched on after an alarm transmission, the siren is automatically switched off so the central station can listen and talk to the premises.

PAGING AND LISTENING

By accessing the telephone menu, you can use an inside or remote phone to talk (page) and listen to someone on the premises.

From the main telephone menu choose the 8 (PHONE).

To talk or listen to the premises, press the 3 (INTERIOR).

- If no key is pressed, the system will automatically switch to listen mode.

To talk to someone at the premises, press the 2 key.

To listen to the premises, press the 8 key.

- When complete, press * to return to the main telephone menu.

If no tones are detected within the 90 second disconnect period, the module will switch off and you will return to the main telephone menu.

ANNUNCIATION OF ALARM

The Voice Alarm Module enables the system to speak the type of alarm and zone over a speaker on premises. When an alarm first occurs, the siren is activated. After a few seconds, the siren is turned off and the type of alarm is announced. The siren is then reactivated. After a few seconds, the siren is again turned off and the violated zone is announced. The siren is then reactivated. This process is repeated until the alarm is disarmed or reset.

Note: During central station communication (while the system is reporting an alarm to the central station), voice alarm notifications are temporarily suspended. After the successful transmission of the alarm to the central station, voice alarm notifications are restarted.

SPEAKER VOLUME CONTROL

The volume of the audio can be controlled by adjusting a variable resistor on the module. Use a small screwdriver to adjust R35 labeled "Speaker Volume".

Do not adjust R59 labeled "Audio Cancel". This variable resistor it is adjusted at the factory to its optimal setting.

SPECIFICATIONS

DIMENSIONS:	5.5" x 3.25"
OPERATING VOLTAGE:	6 to 14 VDC
OPERATING CURRENT:	500 mA maximum
SPEAKER IMPEDANCE:	8 Ω
AGC RANGE:	-22 dbm to +10 dbm
REQUIRED MICROPHONE TYPE:	Condenser w/ built-in preamp